



## Moulds and reproductions

**Resins for moulding and modelling**  
Polyurethane elastomers · Silicone elastomers · Epoxy resins

# Moulds and reproductions



HI. Willibrord

## Contents

Moulds and reproductions .....	2-5
Types of moulds .....	6
Suitability / handling / repair / reproductions .....	7
Step by step .....	8-13
Solid mould – one-piece (liner) .....	14
Solid mould – one-piece (case mould) .....	15
Solid mould – two-piece .....	16-17
Shell mould – one-piece, cast method .....	18-19
Shell mould – two-piece, cast method .....	20-23
Shell mould – one-piece, coat-and-smooth method, horizontal .....	24-25
Shell mould – two-piece, coat-and-smooth method, vertical .....	26-29
Mould construction terminology .....	30
How to select the appropriate mould technology ..	31
Mixture tables .....	32-33
Application examples .....	34-35

Our product range contains 2 groups of products that can be used for elastic moulds:

- **Polyurethane elastomers (PUR)** and
- **Silicone elastomers (SI)**

Both of them are elastic, rubber-like, two-component synthetic substances that set or vulcanise at room temperatures (**Room-Temperature Vulcanisation = RTV**). Each provide special properties in their own right to meet mould making requirements in different ways.

The difference between the two starting materials is less in the way that it is handled and much more than in the technical and chemical aspects and in the price. Generally speaking, the differences are as follows:

- PUR is generally cheaper
- PUR is more resistant to cemented materials (concrete, mortar, render)
- PUR is heat-resistant up to around 65 °C
- SI is generally self-releasing
- SI can be applied to mildly damp surfaces
- SI is more heat-resistant (up to approx. 200 °C, depending on type)
- SI has a “softer” internal structure and is therefore better suited for more delicate work.

With silicone elastomers we also differentiate between

- Vulcanisation by condensation (SI-KV) and
- Vulcanisation by addition (SI-AV)

The difference is that elastomers vulcanised by condensation will have alcohol split off during the vulcanisation process. This process causes a loss in mass, therefore also causing the vulcanised product to shrink; this may be up to 5%. Moreover, the moulds can only be used once the alcohol has fully evaporated.

The time needed is also considerably dependent on the type and compactness of the mould. Elastomers vulcanised by condensation (KV types) also need small amounts of dampness to be fully cured, or else the surface, when exposed to the air, will remain sticky. Adding water does not help here; instead, the relative humidity must be increased, using evaporators or atomisers for example. Simply laying out damp cloths will often help.

Elastomers vulcanised by addition (AV types), on the other hand, do not experience a loss of mass in this way and are ready for use in many cases right after the curing process. However, certain substances or materials that adhere to the model or are present in the air may negatively impact the function of the catalyst for the AV types and cause problems with the curing.

Even though it may be possible from a purely technical standpoint to create both PUR and SI moulds on practically any base, Table 1 can nonetheless help to select the most suitable material.

In many cases the choice of material is not critical when deciding which material is better suited to creating a mould of the model. More important is which material is going to be poured into the elastic mould to make the replica later on. Table 2 provides assistance in deciding.

## Surface

A useful mould requires the surface of the model to be suitable. An evaluation of the surface in particular must therefore be made. An ideal surface is clean, dry, non-absorbent and firm. If the base does not have these properties, measures should be taken to ensure that these conditions are met. If this is not done, it is not possible to exclude problems arising when using the mould and when producing the replicas.

It must be noted, however, that each measure will affect the surface characteristics of the model. Therefore, it must be checked whether such changes are permitted or whether the model must be retained in its original state, which may prevent a mould from being created.

Table 3 shows which base properties are frequently encountered when creating moulds and which measures should be taken to create a suitable base.

### Release agent

PUR generally requires a release agent to separate the mould from the model. Release agents must also be used when creating the replicas. Before the elastomer is poured into the mould or applied onto the mould, the release agent must be fully ventilated and dry. Please refer to Tables 4 and 5 to determine which release agents are suitable for your purpose.

Although SI is generally self-releasing and therefore does not require a release agent, any substances on the model may stick. For this reason, tests should be conducted beforehand on a suitable part of the model.

When two compounds are in contact with one another, there may be incompatibilities and therefore also problems with reactions (inhibition), even when using a release agent. For this reason, it is recommended that tests always be conducted beforehand in these cases as well.

Surface	PUR mould creation	SI mould creation
Stone	X, limited	X, limited
Concrete / concrete block	X	X
Mortar / render	X	X
Plaster	X, limited	X
Clay	X, limited	X
Glass / ceramics	X	X
Wood / composite wood	X	X
Modelling clay	X	X
Hard synthetics	X, limited	X, limited
Soft synthetics	X, limited	X, limited
Paint / coating	X, limited	X, limited
Textiles / leather	X	X
Paper / cardboard	X	X
Metals	X	X, limited

**Table 1**

Replica made of	PUR mould	SI mould
Plaster	yes	yes
Mortar / concrete	yes	limited
<b>Casting resin</b>		
- Epoxy resin, cold-curing	yes	limited
- Methacrylate	limited	limited
- Polyester, unsaturated	limited	limited
- Polyurethane	yes	limited
- Silicon, vulcanised by addition	no	yes
- Silicon, vulcanised by condensation	yes	yes
Metal alloys	no	limited
Wax	no	yes

**Table 2**

Condition of surface	Measure
clean	seal
dirty / patinated	clean, seal
absorbent	clean, seal
non-absorbent	clean
dry	clean, seal
damp	dry, clean, seal
firm	clean, seal
loose	clean, fix in place, seal
untreated	clean, seal
treated	clean, check compatibility
solvent-resistant	clean
non solvent-resistant	clean, check compatibility

**Table 3**

# Moulds and reproductions

## Release agent for mould creation (model : elastomer)

Table 4

Surface	PUR mould	SI mould
Stone	mould wax	SI release agent
Concrete / concrete block	mould wax	not required
Mortar / render	mould wax	not required
Plaster	polishing wax, if dry	not required
Clay	mould wax, if dry	not required
Glass / ceramics	mould wax	SI release agent
Wood / composite wood	mould wax	not required
Modelling clay	mould wax	not required
Hard synthetics	mould wax, if solvent-resistant	not required, but risk of inhibition
Soft synthetics	mould wax, if solvent-resistant	not required, but risk of inhibition
Paint / coating	mould wax, if solvent-resistant	SI release agent when using silicate paints
Textiles / leather	mould wax	not required
Paper / cardboard	mould wax	not required
Metals	mould wax	not required, but risk of inhibition

### RECKLI Mould Wax

A fine solvent-based hard wax for safely separating when creating moulds or liners from RECKLI PUR elastomers

### RECKLI Polishing Wax

Solvent-based liquid wax for polishing model surfaces, particularly on plaster

### RECKLI SI Release Agent

Water-soluble release agent for highly absorbent bases to prevent any adhesion when using RECKLI SI elastomers, prevents discolouration of the originals and can be washed off again with water once the mould has been created

## Release agent for the production of replicas (elastomer mould : replica)

Table 5

Replica made of	PUR mould	SI mould
Plaster	GTM plaster release agent	not required
Mortar / concrete	TL / TL-SO / TL-W release wax	not required
<b>Casting resin</b>		
- Epoxy resin, cold-curing	mould wax	not required
- Methacrylate	mould wax, limited	limited
- Polyester, unsaturated	mould wax, limited	limited
- Polyurethane	mould wax	limited
- Silicon, vulcanised by addition	not possible, inhibited	limited
- Silicon, vulcanised by condensation	not required	not required
Metal alloys	not possible (heat resistance)	limited
Wax	not possible (heat resistance)	not required

### RECKLI TL Release Wax

High quality, solvent-based wax for safely separating cement-based replicas from RECKLI PUR elastomer moulds

### RECKLI TL-W Release Wax

Water-based, environmentally friendly release agent for separating cement- and mortar-based replicas from RECKLI PUR elastomer moulds

### RECKLI Mould Wax

For safe separation when producing replicas from composite resins on RECKLI PUR elastomer moulds

### RECKLI TL-SO Release Wax

Like TL release wax, but with an additional chemical effect for cases when the concrete needs to remain on the elastomer mould for a particularly long time

### RECKLI GTM Plaster Release Agent

Water-based, environmentally friendly release agent for replicas made of plaster on RECKLI PUR elastomer moulds

### Delivery and storage

RECKLI two-component elastomers are supplied as double drums or as pairs of drums of different sizes together with the hardener. With the double drums, the hardener is supplied in plastic bottles. The bottles are in the lid of the container. With the pairs of drums, the hardener is supplied in separate cannisters. Once opened, drums must be closed so that they are airtight.

The storage stability period specified in the information sheets relates to unopened drums when stored in closed rooms with temperatures of +18 °C. If this storage period is exceeded or if the storage conditions change, a pre-test must be checked to determine whether the reactivity has been impaired.

### Processing

When handling our elastomers, ensure that the area is clean and that all contact with dampness is avoided.

The quantity of each of the components, the hardener and the base component has been determined precisely on the basis of the other. The mixing ratio is always calculated according to parts to weight, not parts to volume. Should only part of the quantity be used, a set of scales is indispensable for maintaining the mixing ratio. Do not pour any partial quantities that have already been poured out back in. Failure to maintain the correct mixing ratio will regularly lead to undervulcanisation or overvulcanisation, which can seriously impact the quality parameters, thereby making the mould unusable.

A slow-running drill with a stirring paddle is suitable for mixing the two components. Small quantities are mixed by hand using a spatula or wooden mixing spoon.

The base component is shaken thoroughly before mixing. The hardener is then added to the base component in the specified proportion and both substances are mixed together to form an even mixture. To prevent incorrect mixtures, the material from the inside walls of the container must be added to the mixture. It is beneficial if the mixture is poured into another mixing container and stirred again. Otherwise, we recommend that the hardener be placed in a mixing container, that the base component be poured onto that and that both components then be stirred to form an even mixture; when emptying, the mixture should then be allowed to flow out and not be scratched from the sides of the container.

The processing times specified in the information sheets relate to a material, ambient and base temperature of +21 °C and the appropriate mixture quantity. Higher temperatures accelerate, lower temperatures slow down the hardening process. The material temperature of the elastomers should generally not fall below +18 °C and not exceed +30 °C during processing. Therefore, cool storage is required with higher temperatures, while a warm water bath (the tightly closed container placed in warm water) enables a favourable processing temperature to be achieved when the ambient temperature is low. The processing time is also dependent on the quantity of mixture and the storage duration of the material.

The elastomers should generally not be processed at temperatures below +10°C, as the process of vulcanisation may “come to a complete stop”.

Hardener and base materials must always be processed in their original condition. Never add fillers or thinners. These would change the physical and chemical properties of the material in a way that cannot be controlled.

### Safety information

Protect skin and eyes from any hardener and plastic that may splash or spray around. Please observe the notes regarding the German Hazardous Materials Ordinance and the German Ordinance for the Transport of Hazardous Materials on the labels and the relevant DIN safety data sheets.

### Cleaning equipment

Use RECKLI EK-PU thinner to clean equipment and tools and remove undesirable traces of PUR. Cleaning must be thorough. It is not sufficient to simply place the tools in the thinner.

SI elastomers in their fresh state can also be removed using RECKLI EK-PU thinner. However, it is more beneficial to allow the SI elastomers to harden, as they then separate themselves of their own accord and can simply generally be pulled off the base.



Creation of a mould of an ichthyosaur (“fish lizard”)

# Which types of mould are there?

We generally differentiate between solid moulds, which may also be referred to as solid casts, and shell forms, which are also often referred to as shell mould casts. Both types of mould may consist of a single piece, of two parts or even of several parts.

## Solid one-piece moulds

If a model is only textured on one side, creating a mould is a very simple process. Once the model has been prepared, a frame that extends approx. 8-10 mm above the highest point of the model's texture is placed around the model, the selected release agent is applied as necessary to the model and frame, the release agent is allowed to ventilate fully until it is dry, and the elastomer is poured into this mould once it has been correctly mixed. Once hardened, generally after 24 hours, the elastomer mould can be removed from the model and be prepared for replica casting. These types of moulds are also known as formliners. The elasticity of these formliners enables the model to not only to reproduce right-angled progressions in the texture, but also to reflect even the smallest dips in the texture, all the while avoiding damage to the replica during the mould creation process, provided that it is sufficiently stable.

If the model is textured not only on the front, but also on its sides, solid moulds can also be used for a certain degree of texturing. In these cases, we also refer to these as case moulds. However, if the sides of this box have somewhat deeper textures, it will no longer be possible to "peel" the replica out of such a mould; in these cases, a mould consisting of two or even more components must be produced.

## Solid moulds consisting of two or more pieces

This type of mould is used if the model needs to be moulded on all of its sides and does not have any dips or back tapers that are too pronounced. Whenever these moulds are used, the expected position of the mould seam line and the expected position of the opening for pouring the replica's casting substance into must be given due consideration. It may also be necessary to add ventilation holes or ducts. The mould seams for moulds consisting of two or more parts should generally be bound together to improve the alignment of the mould parts and prevent or even completely avoid slipping and sliding when the replica material is poured in.

## Shell moulds

Shell moulds are also known as shell casts. These are thin moulds that are always used in cases where elastomer material needs to be saved or if a thicker mould would cause problems with removing the mould for technical reasons, whereby the solid form of the mould would cause the model, the mould itself or the replica to be damaged. Shell forms can be used with both the casting method and the coat-and-smooth method. They often consist of several parts but may also consist of a single part. Depending on the type of model, they are either designed to be horizontal (lying down) or vertical (standing up). As with solid moulds, shell moulds must be clamped together at the seams between parts so that the parts of the mould can be better aligned, the leaktightness can be improved and a sliding of the parts of the mould against one another can be prevented when pouring in the replica material. Depending on the size, shell moulds will generally require a support mould to support the forces exerted by the mass of the casting material used for the replica.

## Support moulds

Mould supports are forms adapted to the shell moulds that provide the necessary support for the thin elastic moulds when pouring in the replica casting material. They may be solid or thin-walled. Depending on how the shell mould is constructed, mould supports may consist of one or several parts. Plaster or even concrete is often used as a material for support moulds. The disadvantage of plaster and concrete is their high weight. With models of a large volume, mould supports made of these materials must be split into several parts, even though the nature of the model does not make such a break-up necessary; this division is necessary simply because it could not otherwise be carried or transported. For this reason, an alternative used here is fibre-reinforced putty ramming mixture; although these are solid in nature, they are also often lighter. Another alternative is to dilute casting resins with lighter filler materials to reduce the weight. Fibre-reinforced laminating and putty resins may also be used for weight reasons (polyester, epoxy resin) to create thin shell moulds. Depending on the type and size of the mould, these thin shells are reinforced and strengthened by rigid supported such as bars or sheets made of wood or steel.



Church Bell of Edenkoben dated 1624

# Suitability / handling / repair / reproductions

## Suitability of moulds

After around seven days, the vulcanised product will have fully hardened, thereby achieving its full physical and chemical resilience. However, depending on the elastomer used and the materials from which the replica is to be created, it may be possible to use the elastomer moulds after just around 24 hours. This applies in particular to replicas made of plaster or concrete. With casts made of resins, however, it is imperative that tests be performed beforehand to determine whether the cast is suitable for use at an earlier stage.

## Handling / storage of the moulds

Even if the mould has been created with the utmost of care, there is no way to exclude with absolute certainty the possibility that elastomer moulds or mould supports consisting of two or more pieces may fail to align properly over the course of their use or simply when in storage; variations in temperature, expansion and compression arising from stresses and even normal aging all have an effect on this. For this reason, ridges may appear on the seams between the parts, making the refinement of the replica necessary.

Moulds should be stored in dry conditions at room temperature and be protected against exposure to sunlight. It is a good idea to leave a replica in the mould to maintain the stability of the form. However, the replica must be first removed as usual and then replaced in the mould in its precise fit once it has been fully cured.

## Suitability of moulds

PUR moulds can be cleaned with the same release agent that is used to remove the relevant replicas from the mould. Here a clean, lint-free cloth is dipped into the release agent and the mould is rubbed down thoroughly. Allow the solvent contained in the release agents to ventilate and dry out completely before re-using the mould or storing it.

SI moulds can be easily washed out using clean water with a little washing-up liquid. Once clean, use a lint-free cloth to dry the mould.

## Repairing moulds

Places to be repaired must generally be free of oil, grease and wax residues, and there must also not be any other contaminations sticking to the mould. It is a good idea to roughen the area to be repaired with sandpaper. This decisively improves the bonding of the repair material.

In general, however, it must be considered that a repaired mould can never fully replace an undamaged mould. There is always the risk that the repaired spot will not be able to withstand the stresses exerted by the replica casting material.

The elastomer itself from which the mould has been created presents a suitable repair material.

However, for PUR moulds, RECKLI Elastofiller, a specially developed repair and adhesive putty that enables moulds to be re-used again after just 6-8 hours, is particularly suitable.

For SI moulds, ordinary one-component silicone sealants and adhesive pastes are suitable for use as well as the relevant 2-K silicones, although a vulcanisation time of around 48 hours should be allowed when using 2-K or 1-K silicone repair materials before the mould is used again.

## Reproductions

The reproductions of models are known as copies or replicas.

The most common materials for replicas are plaster, cement mortar or concrete. These replica materials do not pose a problem for moulds made of PUR elastomers if the appropriate release agent is used. With SI elastomers, the use of mortar or concrete can lead to separations in the form of whitish deposits on the replicas, although vulcanisation by addition is less susceptible to this than vulcanisation by condensation.

When using any type of casting resin as a reproduction material, appropriate preliminary tests should always be conducted for both PUR and SI moulds, as compatibility is dependent on a great number of different parameters, e.g. resin filler ratios, reactivity, heat development, curing duration, volume of the replica and also the expected frequency of use of the moulds. Due to the intensive reactivity (heat development) of the casting resins, many types are only suitable for low-volume replicas. Therefore, the information provided by the manufacturer should always be observed.

For metal alloys or waxes that melt at high temperatures, the low temperature resistance of PUR moulds excludes their use. SI moulds are more suitable for this purpose.

PUR moulds are not suitable for foods (e.g. chocolates). SI moulds can be used for this under certain circumstances, if it can be ensured that any pieces that break off have been removed from the moulds. Here it generally helps to temper the SI mould, e.g. by exposing it to 200 °C.

# Step by step ...



1 | Determining the parting lines



2 | Paste applied as a rib to the parting lines



3 | Smoothed out and sealed separation rib



4 | Application of the first silicone layer

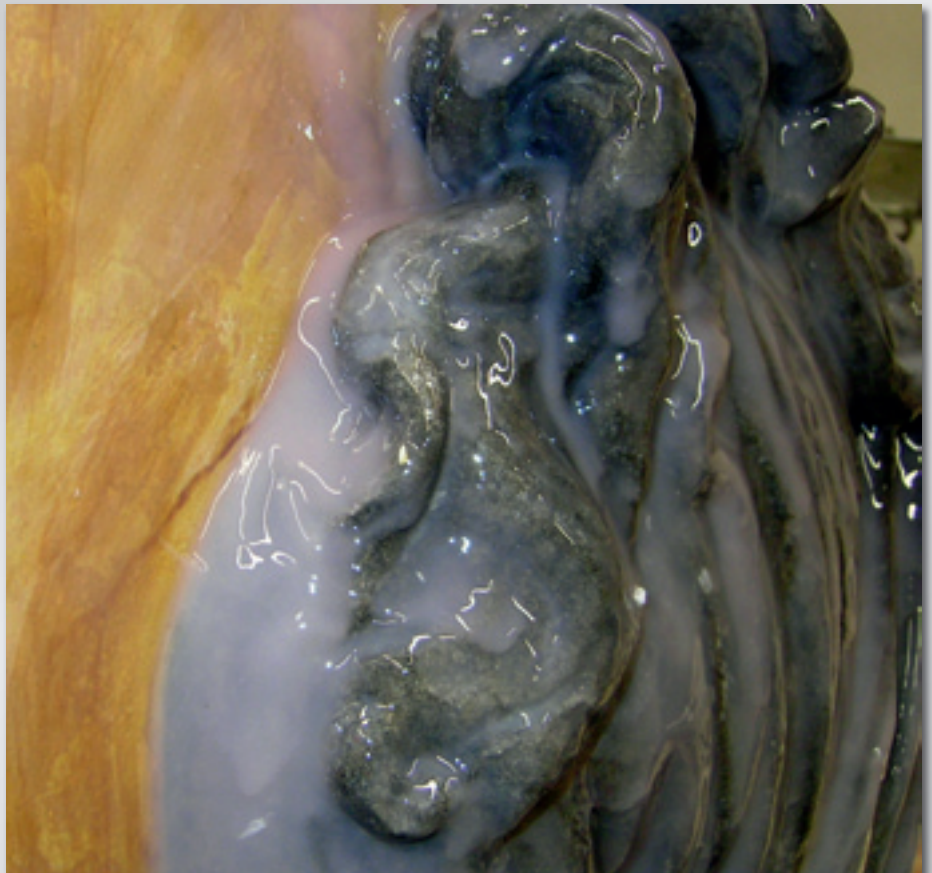

5 | Applied silicone layer





6 | Placing foam fillers in back tapers or heavy dips



7 | Application of the second silicone layer



8 | Fixing the clamp in place



9 | Apply third silicone layer and smooth out



10 | Smoothed out final silicone layer



11 | Inserting restraint cord loops used for fixing in place in the mould support

# From the original ...



12 | Application of Epoxi-GF filler



13 | Smoothed out Epoxi-GF shell



15 | First half of mould finished



14 | Removal of separation rib



16 | Supporting and clamping of first half of mould



17 | Applying the third silicone layer to the second half of the mould



18 | Foam fillers for the back-tapering



19 | Applying the reinforcement using EP-F Type VB supporting material



20 | Finished reinforcement



21 | Half-shell, inverted

... to the reproduction.



22 | Mould ready for reproduction casting



23 | Looking inside the mould



24 | Removing the supporting shell from the silicone shell

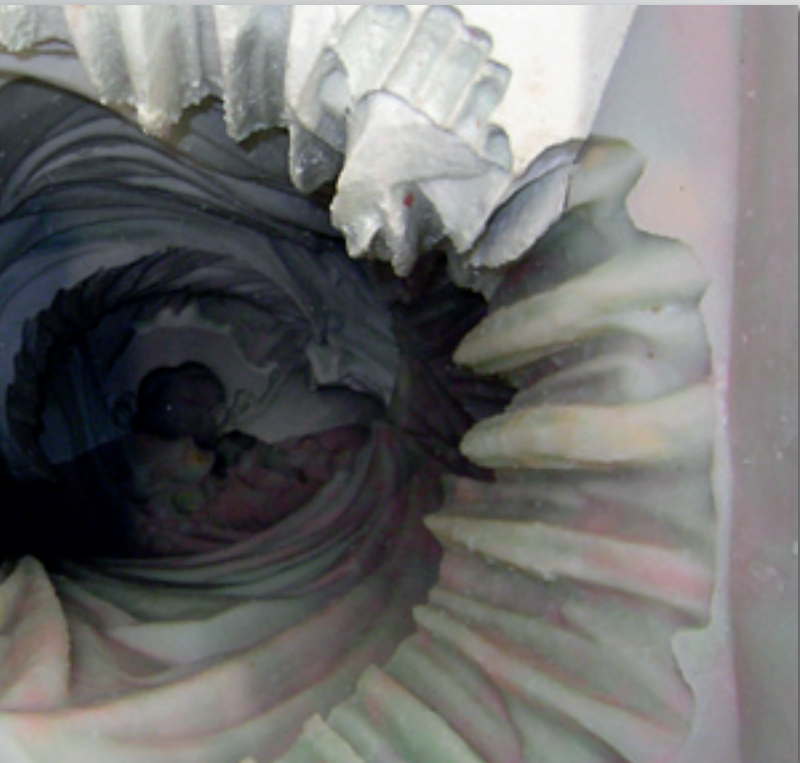

25 | Stripping the silicone coating off the replica



26 | Original and replica

# Work steps and visual illustration

## Solid form – one-piece (formliner)

- Place blocking frame around the pre-treated model and fix it in place
- The frame must be at least 8 mm taller than the highest point of the model's texture
- Seal the frame as necessary
- If necessary, apply release agent as appropriate to the model and frame
- Allow the release agent to dry
- Stir the elastomer and pour into the deepest point of the model from as high a position as possible with a narrow stream, and allow to flow through the model from there.
- Cover the highest point of the model by around 8 mm
- Smooth out the elastomer as necessary if using a model with a large surface
- Remove the frame once the elastomer has cured (around 24 hours)
- Remove/pull off the liner or solid mould

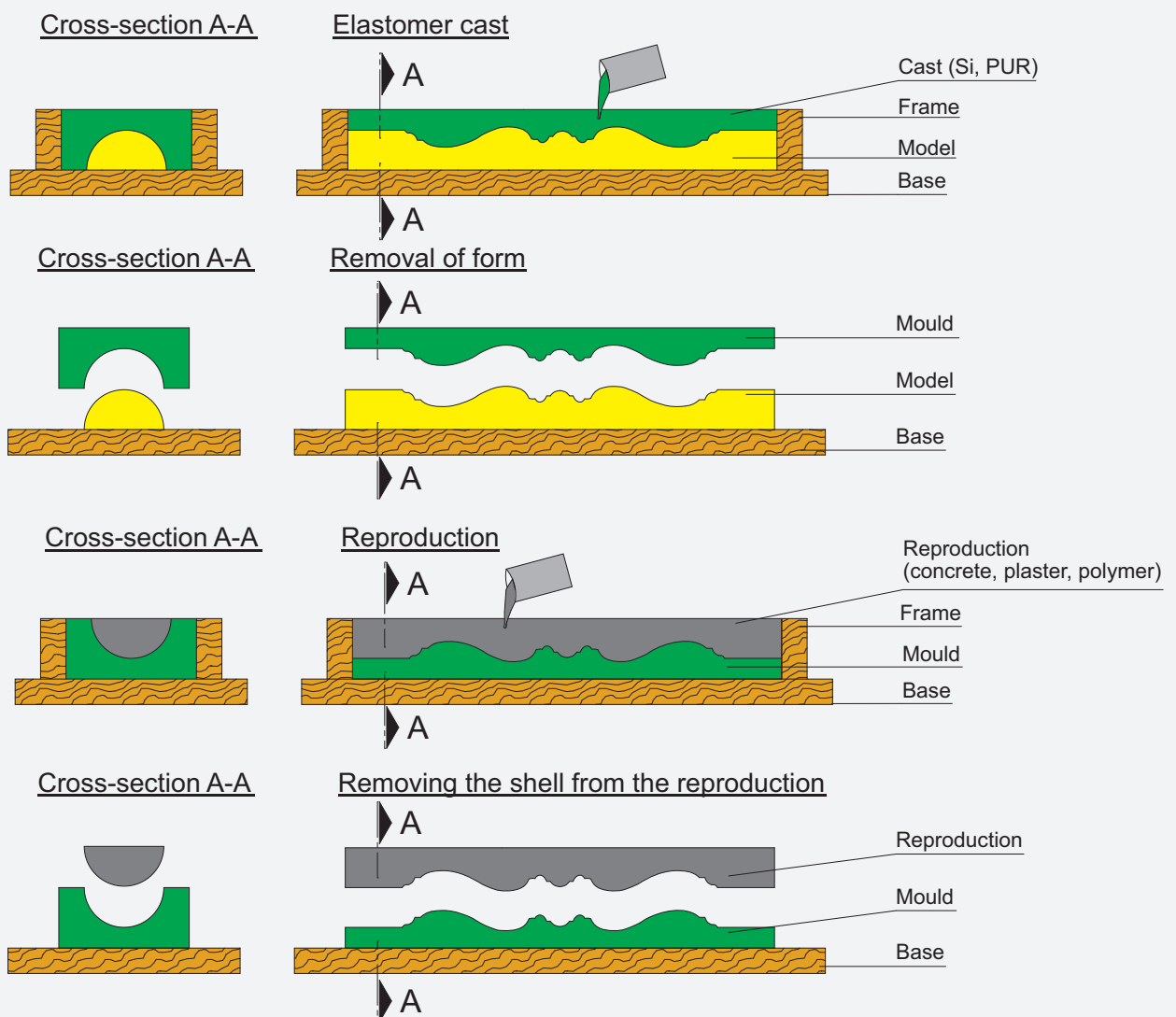

## Solid form – one-piece (box form)

- Place pre-treated model on a base plate and clamp in place
- Place blocking frame around the model and fix in place
- Distance of frame to model at least approx. 2 cm
- The frame must be at least 10 mm taller than the highest point of the model
- Seal edges and joints of frame
- If necessary, apply release agent as appropriate to the model and frame
- Allow the release agent to dry
- Stir the elastomer and pour into the box from as high a position as possible with a narrow stream
- Only allow to flow into the deepest point of the model and allow the material to rise from there to all areas of the model
- Cover the highest point of the model by around 10 mm
- Allow the elastomer to harden (approx. 24 hours)
- Remove the frame
- Carefully pull off the elastic form from the model

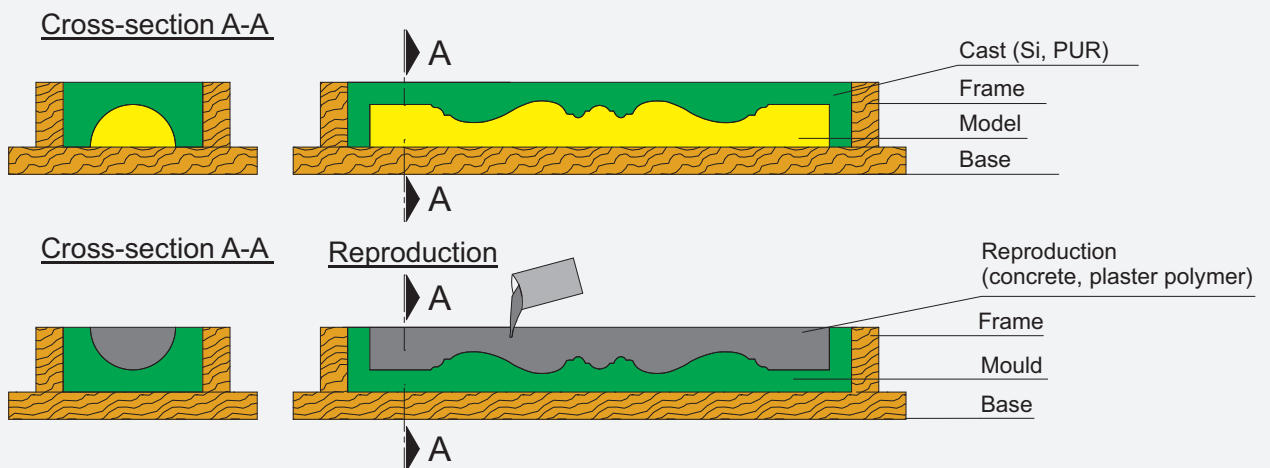

### Important information for preventing trapped air

It is generally inevitable that air stirred into the elastomer matrix, air that remains on the model and cannot escape, or air that escapes from the model will cause bubbles on the surface of the elastomer mould. While it would be possible to evacuate any air stirred in using vacuum techniques, this takes considerable time, incurs additional expense and is highly impractical with larger moulds. Applying an initial layer of elastomer using a short-bristle brush or, when using SI moulds, massaging it in by hand can reduce the formation of bubbles considerably.

**Also, when using solid moulds, pour it into the deepest point of the model from as high a position as possible with a narrow stream, and allow it to rise and flow through the entire model from there.**

# Work steps and visual illustration

## Solid mould – two-part, cast method

- Determine the parting lines on the model
- Place pre-treated model on a base plate and clamp in place
- Place blocking frame around the model and fix it in place
- Distance of frame to model at least approx. 2 cm (side limits)
- The frame must be at least 10 mm taller than the highest point of the model
- Seal edges and joints of frame
- Protect the half of the model to be embedded as far as the parting line with foil as necessary
- Insert or pour the embedding material (sand, plastic, mortar, modelling wax, clay, plasticine etc.) to the highest separating line possible, smooth out, apply pressure
- Allow the embedding material to set and refine as necessary along the parting line
- Fix clamps to the embedding material (bars, pins, cords, shells, cavities) to enable the halves of the form to align better
- Position and clamp in place the tubes needed for the filling and ventilation of the replica material to be applied later
- If necessary, apply release agent as appropriate to the model, visible surfaces of the embedding material and the frame
- Allow the release agent to dry
- Mix the elastomer and pour into the box mould from as high a position as possible with a narrow stream
- Always pour to only one position, if possible the deepest in the mould, and allow the material to flow through all the areas of the model
- Cover the highest point of the model by around 10 mm
- Allow the elastomer to harden (approx. 24 hours)
- Lay the entire mould down on its back, complete with the model
- Remove the box frame and base
- Remove the embedding material and protective foil
- Do not remove the first finished half of the mould from the model
- Place the model down on its back together with the first half of the mould
- Reattach the base and box frame
- Apply release agent as appropriate to all visible surfaces on the first half of the mould in order to prevent the two mould halves from sticking to one another
- If necessary, apply release agent again to the model and also to the mould frame
- Allow the release agent to dry
- Position and clamp in place the tubes needed for the filling and/or ventilation of the replica material to be applied later if necessary
- Mix the elastomer and pour into the box mould from as high a position as possible with a narrow stream
- Always pour to only one position, if possible the deepest in the mould, and allow the material to flow through all the areas of the model
- Cover the highest point of the model by around 10 mm
- Allow the elastomer to harden (approx. 24 hours)
- Remove the mould frame
- Pull the upper and lower halves of the mould off the model
- If you have forgotten to apply tubes for filling and ventilation, drill holes through the elastomer at the appropriate places



Cross-Section A-A

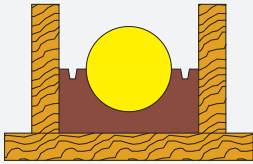

Including embedding in the cast

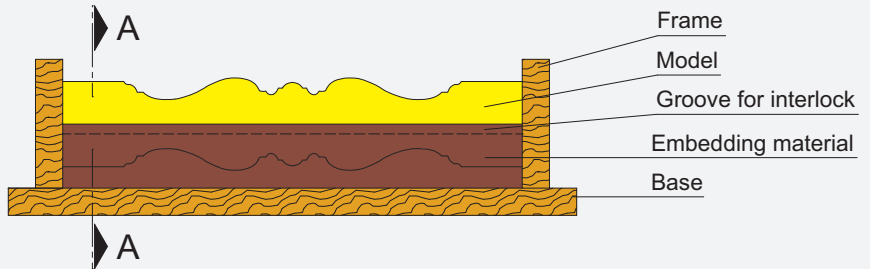

Cross-Section A-A

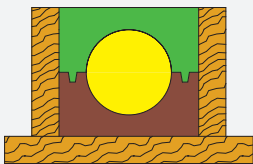

Elastomer cast of the first half of the mould

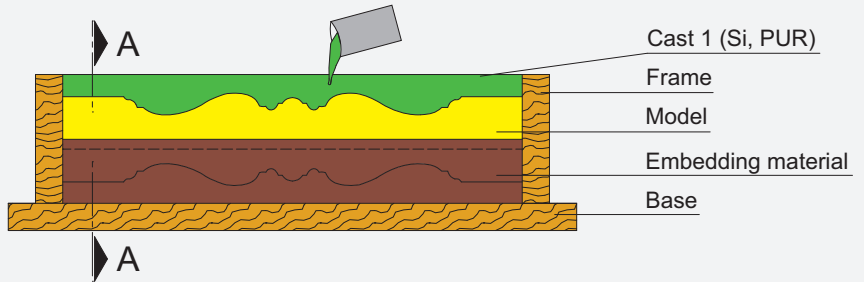

Cross-Section A-A

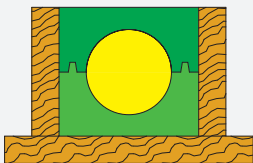

Elastomer cast of the second half of the mould

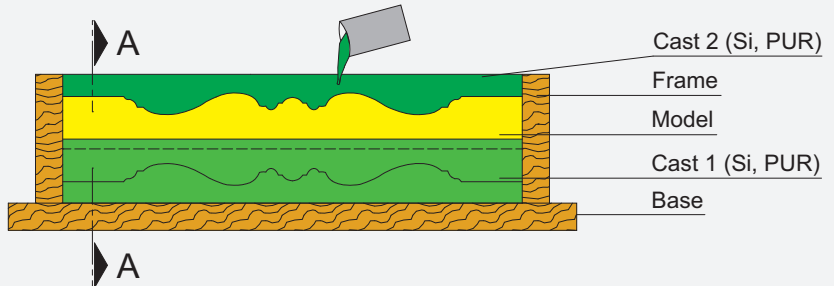

Cross-Section A-A

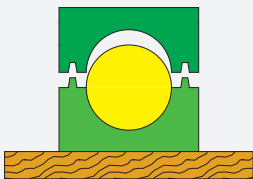

Removing the two-part mould

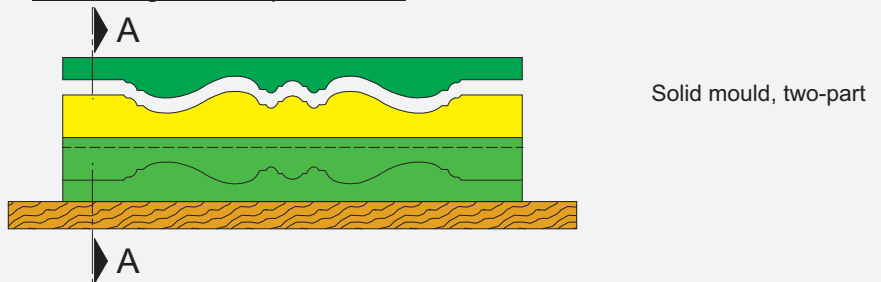

# Work steps and visual illustration

## Shell mould – one-piece, cast method

- Clamp pre-treated model onto a base
- Apply release agent to model or lay thin foil over model
- Apply spacer material (clay, plasticine) with a thickness of around 10 mm
- Place the mould frame around the model to pour in the support mould material, fix it in place and seal
- Ensure that the frame is sufficiently tall and is sufficiently far away from the model (approx. 3 cm depending on the mould support material)
- Coat back of spacer material with release agent
- Pour support mould material (plaster, mortar, resin) into the mould frame
- Alternatively, apply supporting shells made of fibre-reinforced plastics (polyester, epoxide), which removes the need for the mould frame
- Apply reinforcements to the plastic supporting shell (wooden bars, iron sections)
- Fit and fix in place tubes for filling and ventilation
- Remove the shell frame once the support mould material has hardened
- Mark the price position of the support mould on the surface
- Remove the mould support
- Remove the spacer material
- If no tubes for filling and ventilation have been placed, drill through the mould support at the appropriate places (casting holes at the lowest points of the model possible, ventilation holes at the highest points possible)
- Coat the model with release agent if necessary
- Coat the inside of the mould support with release agent if necessary
- Allow the release agent to dry
- Stir the elastomer and apply a first layer to the model using a short-bristle brush, SI elastomers may also be massaged in by hand
- Place the cast support mould over the model and align precisely with the marking on the base plate
- Re-attach mould frame or position smoothed out plastic support shell and fix it in place
- Pour stirred elastomer with a narrow stream (using a funnel) into the casting hole
- Lightly vibrating or shaking the mould can help the elastomer to better ventilate and allow the air bubbles to escape through the upper tubes
- Keep pouring the material in until it can be seen around the ventilation holes
- Allow the elastomer to harden (approx. 24 hours)
- Remove the support mould and shell mould from the model
- Pull the shell mould off the model and place back into the support mould
- Place the shell mould also back into the support mould every time once the replicas have been produced in order to prevent deformations, particularly on shell moulds where the reactions have not yet fully been allowed to run their course

Cross-section A-A



Support mould, solid  
(Plaster, concrete, polymer)

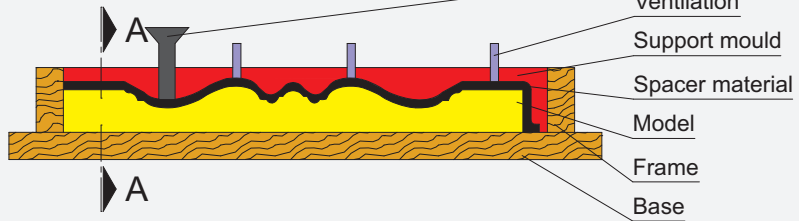

Cross-section A-A

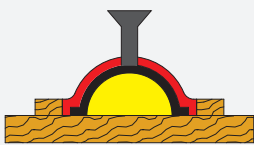

Alternative:

Support mould, glass-fibre reinforced plastic shell

(Polymer ramming material, polymer paste, polymer laminate)

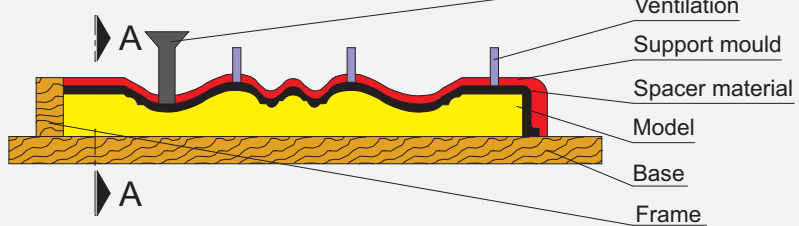

Cross-section A-A

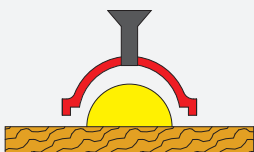

Removal of form

(Removed glass-fibre reinforced plastic supporting shell, spacer material removed)

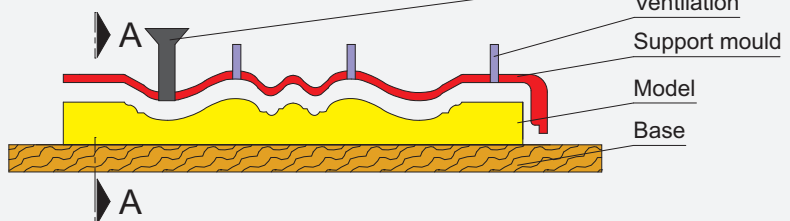

Cross-section A-A

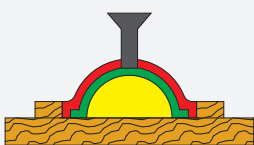

Elastomer cast

(PUR, Si)

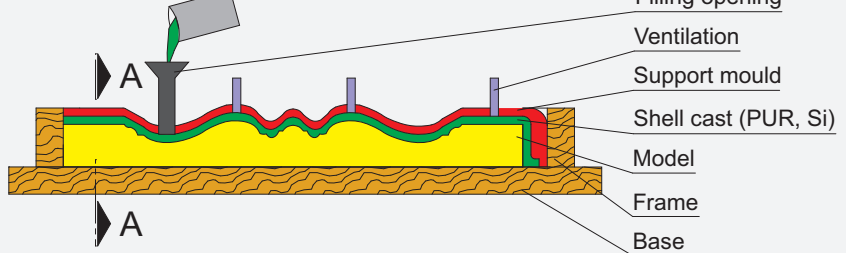

Cross-section A-A



Reproduction (copy, replica)

(Plaster, concrete, polymer)

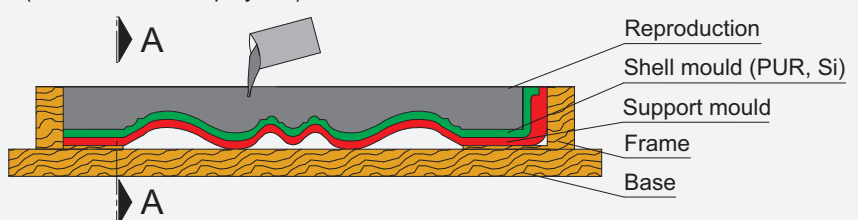

# Work steps and visual illustration

## Shell mould – two-piece, cast method

- Place pre-treated model on a base surface and clamp in place
- Determine and mark parting line on model
- Apply model splitting points as large as possible
- Avoid having line run across smooth surfaces if possible, rather along edges
- Place blocking frame around the model, fix in place and seal (approx. 5 cm distance between model and frame)
- The frame must be at least 3 cm taller than the highest point of the model
- If possible, have the model touch the planned opening for pouring in the replica material

### Embedding

- Protect the lower half of the model to be embedded as far as the parting line with foil as necessary
- Insert or pour the embedding material (sand, plastic, mortar, clay, plasticine modelling wax, etc.) to the highest parting line possible, smooth out, apply pressure
- If a sand bed is planned, apply a layer of plaster to the top of the sand bed as a smoothing layer
- Allow the embedding material to harden and refine as necessary along the parting line
- Fix clamps to the embedding material (bars, pins, cords, shells, cavities) to enable the halves of the form (or parts thereof) to align better
- Position and clamp in place the tubes needed for the filling and ventilation of the replica material to be applied later
- If necessary, apply release agent as appropriate to the model, visible surfaces of the embedding material and the frame
- Allow the release agent to dry

### Finishing the embedding

#### Work step 1 Mould halves

- (1) Apply a thin foil as well if necessary to prevent the model from being soiled by the spacer material
- (2) Apply spacer material (clay, plasticine) with a thickness of around 10 mm to the half of the model
- (3) Create anchor points or sections to ensure that the shell mould is better supported in the support mould
- (4) Ensure that dips and back tapers are also fully covered by the spacer material
- (5) Apply release agent to the spacer material to ensure that it can be better separated from the support mould material
- (6) Allow the release agent to dry
- (7) Pour the support mould material on (plaster, mortar, resin)
- (8) Or apply support mould made of fibre-reinforced plastics (polyester, epoxide), which removes the need for the mould frame
- (9) Apply reinforcements to the plastic support mould (wooden bars, iron sections)
- (10) Remove the frame after the curing process, remove the support mould, spacer material and, if necessary, the protective foil from the first half of the model
- (11) If no tubes have been placed for filling or ventilation, drill holes as appropriate in the support mould
- (12) Apply pouring opening to the lowest point, ventilation holes to the highest points of the model
- (13) If necessary, apply release agent to the model and inside of the support mould
- (14) Allow the release agent to dry
- (15) Stir the elastomer and apply using a short-bristle brush as a first layer onto the half of the model
- (16) Re-attach frame
- (17) Align support mould precisely over the model and fix it in place
- (18) Pour the elastomer into the filling opening from as high a position as possible with a narrow stream (using a funnel)
- (19) If possible, lightly vibrate/shake the model so that the elastomer can flow into all of the finer elements of the model surface without trapping air
- (20) Keep pouring the material in until the elastomer can be seen around the ventilation holes
- (21) Allow the elastomer to harden (approx. 24 hours)
- (22) Remove the frame
- (23) Place the form on its back

- (24) Remove the embedding material
- (25) The first half of the support mould and the first half of the shell mould stay on the model
- (26) Re-attach frame
- (27) If necessary, apply release agent to the second half of the model, to the visible surfaces of the first half of the support mould and to the frame
- (28) Allow the release agent to dry

### Work step 2 Mould halves

- (1-22) Work steps identical with first half of mould
- (23) Remove the support mould and shell mould halves from the model
- (24) Place the halves of the shell mould back into the halves of the support mould that they are precisely aligned
- (25) Clamp the halves of the support mould together in their precisely aligned position (plaster, mortar) or screw them together (polyester/epoxide)
- (26) Place the shell mould also back into the support mould every time once the replicas have been produced in order to prevent deformations, particularly on shell moulds where the reactions have not yet fully been allowed to run their course



*Removal of the shell from a one-piece solid mould made of SI elastomer*

# Shell mould – two-piece, cast method

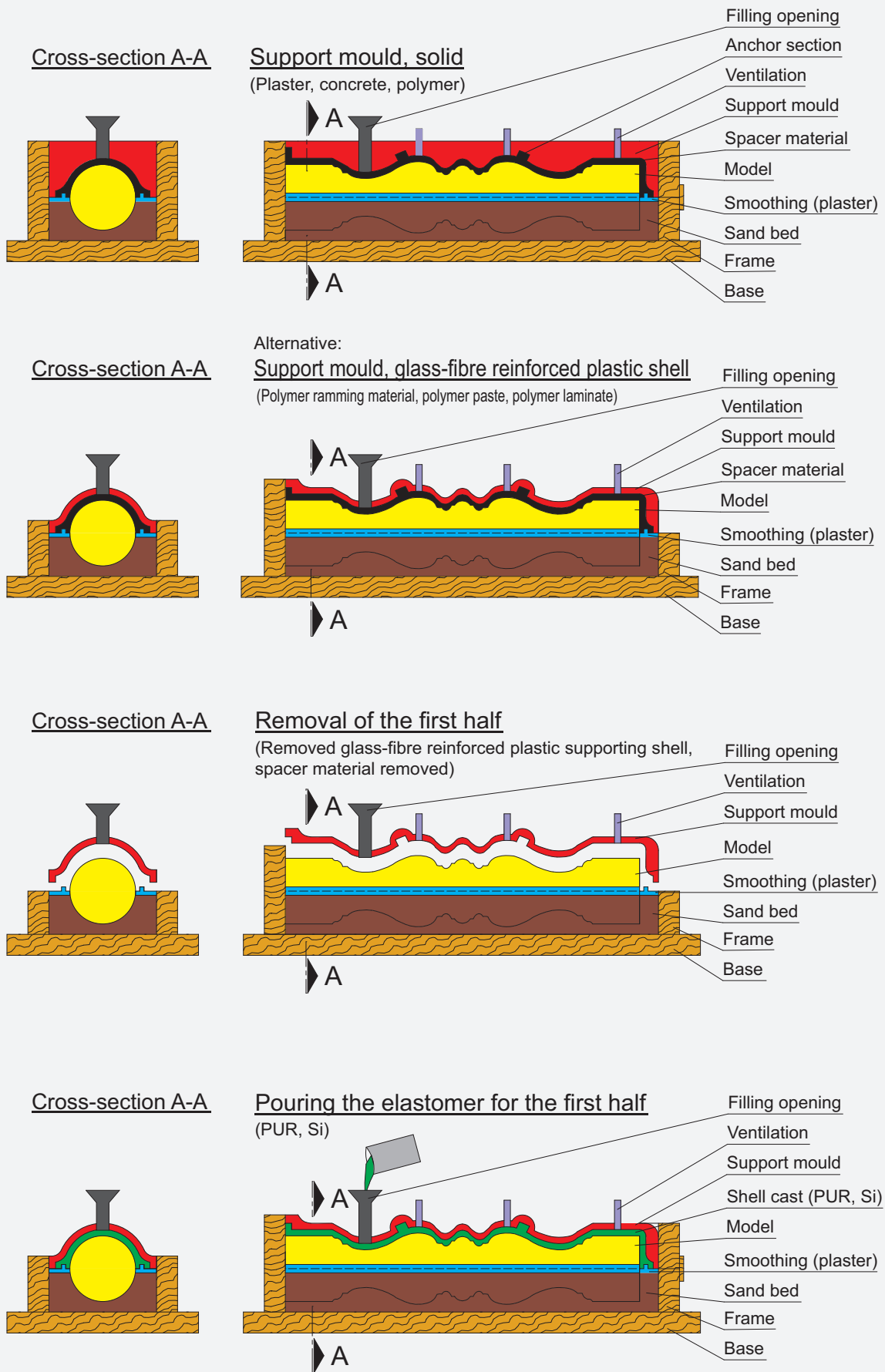

Cross-section A-A

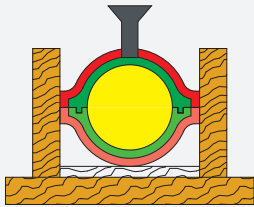

Pouring the elastomer for the second half  
after rotating 180° (PUR, Si)

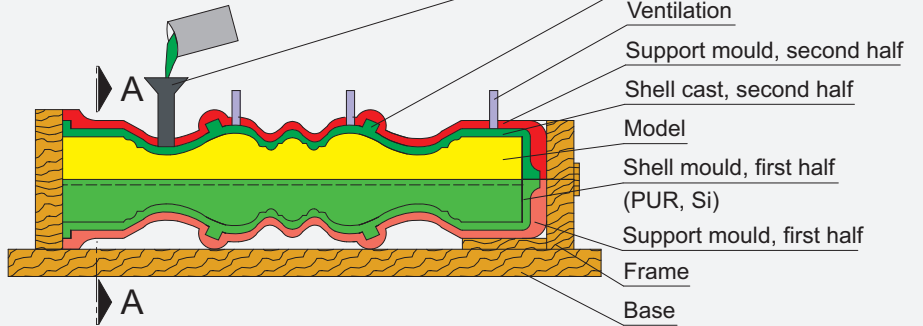

Cross-section A-A

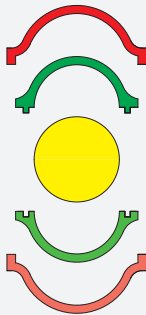

Removal of form in several parts

Removal of glass-fibre reinforced plastic support shell and elastomer shell mould

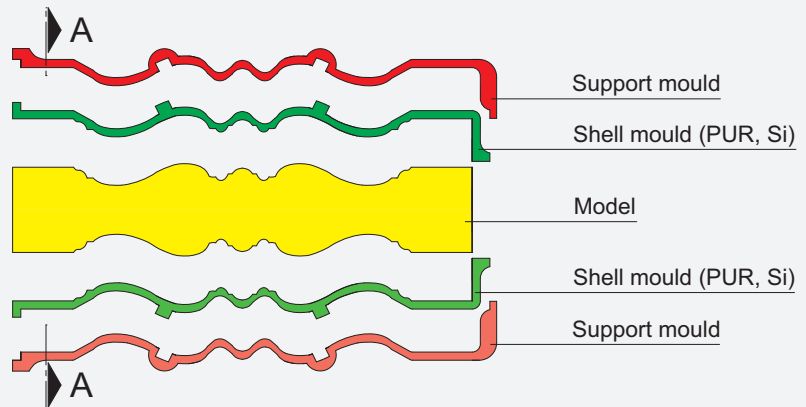

Reproduction

(concrete, plaster, polymer)

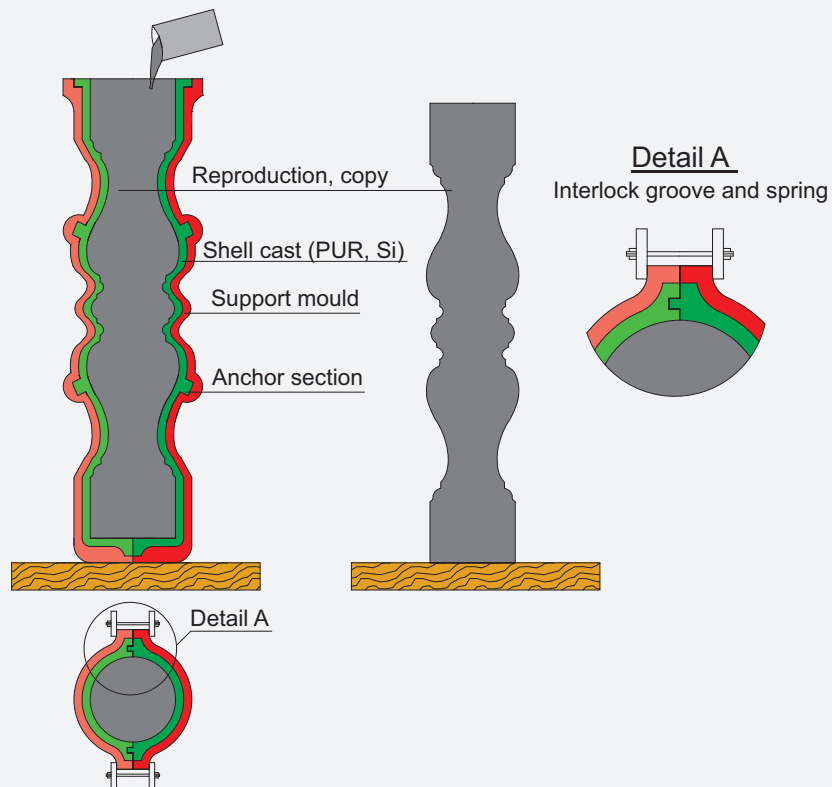

# Work steps and visual illustration

## Shell mould – one-piece, coat-and-smooth method, horizontal

- Clamp pre-treated model onto a base
- If necessary, apply release agent to the model
- Stir elastomer
- Add thickener to make the material slightly thixotropic or use material that is already thixotropic
- Apply liquid or mildly thixotropic elastomer using a short-bristle brush to the model; the first layer can be massaged in by hand with SI elastomers
- Allow this thin coating to react so that the following layer cannot be displaced but is still sticky
- Dye the elastomer for the next layer so that the thickness of the layer is easier to check
- Use a spatula to apply the firm elastomer with a thickness of around 5–15 mm to the still sticky layer
- Insert foam filling into dips to prevent large bulky volumes
- It is a good idea to apply a third layer in the original colour again (to enable the thickness to be checked); in this case, the second layer only needs to be around 3–5 mm thick
- Smooth out the last layer so that there are no burrs, peaks, digs or back tapers and so that the shell mould does not get jammed in the support mould later on
- If there are large or deep back tapers, smooth out the inside of the taper so that a separate wedge and/or plug can be produced and inserted into the firm/rigid support mould later on
- Create interlocks in the final elastomer layer to enable a more solid hold in the support mould (trapezoidal ribs, elevations or dips/buttons, restraint cords)
- Allow the elastomer layers to harden (approx. 24 hours)
- To create the support mould/support shell, do not pull the shell mould off the model
- Apply release agent as appropriate to the back of the shell mould if necessary
- With back tapers and penetrations, apply wedges/plugs made of the support mould material (plaster, fibre-reinforced resins) (epoxide/polyester) and make any necessary adjustments for the following support mould
- Allow the plugs to harden
- Allow the plugs to sit on the shell mould
- Apply release agent again
- Apply support mould
- If necessary, reinforce the support mould by applying wooden bars or steel sections
- Allow the support mould to cure
- Remove the support mould and plugs from the back of the shell mould
- Pull the shell mould off the model and place back into the support mould
- Place the shell mould also back into the support mould every time once the replicas have been produced in order to prevent deformations, particularly on shell moulds where the reactions have not yet fully been allowed to run their course



Cross-section A-A



Coating application

(PUR, Si)

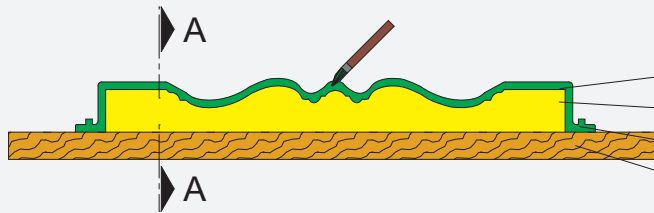

Coating application (PUR, Si)

Model

Interlock (cord)

Base

Cross-section A-A



Support mould, solid

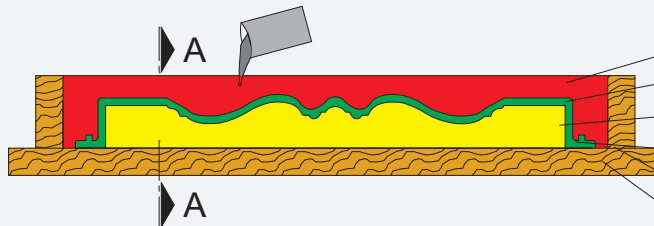

Support mould (concrete, plaster, polymer)

Shell mould

Model

Interlock (cord)

Frame

Base

Cross-section A-A



Alternative:

Support mould, glass-fibre reinforced plastic shell

(Polymer ramming material, polymer paste, polymer laminate)

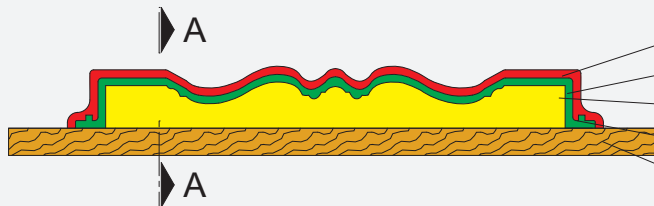

Support mould

Shell mould (PUR, Si)

Model

Interlock (cord)

Base

Cross-section A-A

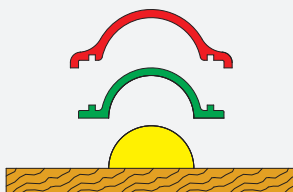

Removal of form

Removed glass-fibre reinforced plastic support shell, shell mould

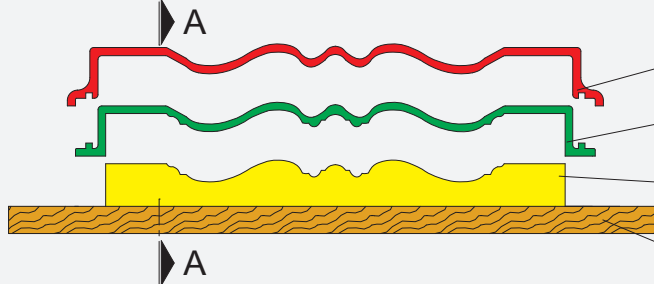

Glass-fibre reinforced plastic mould support

Shell mould (PUR, Si)

Model

Base

Cross-section A-A

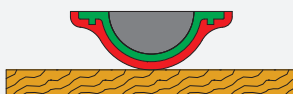

Reproduction

(Plaster, concrete, polymer)

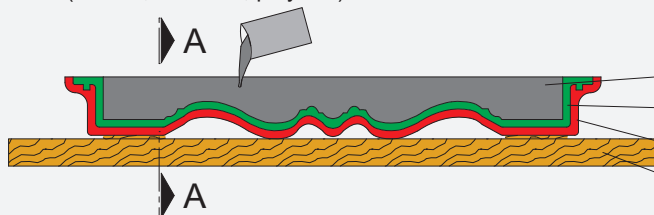

Reproduction

Shell mould (PUR, Si)

Mould support

Base

# Work steps and visual illustration

## Shell mould – two-piece, coat-and-smooth method, vertical

- Place/lay pre-treated model on a base surface and clamp in place
- Determine and mark parting line
- Select mould halves that are as large as possible
- Avoid having line run across smooth surfaces if possible, rather along edges
- Apply model splitting points as large as possible

### If the model can be embedded (generally smaller models):

- Embedding process, see two-part shell mould using cast method (page 20)

### If the model cannot be embedded and can only be placed down:

- Creating the mould in a standing position (vertically)
- If necessary, apply release agent to the model
- Allow the release agent to dry
- Use plasticine or plaster to create a support rib along the parting line, apply pressure and smooth out
- Rib at least approx. 3–5 cm wide and approx. 3–5 cm thick
- Fix clamps to the rib (bars, pins, cords, shells, cavities) to enable the halves of the form (or parts thereof) to align better
- Position and/or clamp in place the tubes needed for the filling and ventilation of the replica material to be applied later

### Same work steps after the embedding or placing down:

#### First half of mould

- (1) Stir the elastomer
- (2) Add thickener to make the material slightly thixotropic or use material that is already thixotropic
- (3) Apply liquid or mildly thixotropic elastomer using a short-bristle brush to the model and rib; the first layer can be massaged in by hand with SI elastomers
- (4) Allow this thin coating to react so that the following layer cannot be displaced but is still sticky
- (5) Dye the elastomer for the next layer so that the thickness of the layer is easier to check
- (6) Insert foam filling into dips to prevent large bulky volumes
- (7) Use a spatula to apply the firm elastomer with a thickness of around 5–15 mm to the still sticky layer
- (8) It is a good idea to apply a third layer in the original colour again (to enable the thickness to be checked); in this case, the second layer only needs to be around 3–5 mm thick
- (9) Smooth out the last layer so that there are no burrs, peaks, digs or back tapers and so that the shell mould does not get jammed in the support mould later on
- (10) If there are large or deep back tapers, smooth out the inside of the taper so that a separate wedge and/or plug can be produced and inserted into the firm/rigid support mould later on
- (11) Create interlocks and anchor sections or restraining cord loops in the final elastomer layer to enable a more solid hold in the support mould (trapezoidal ribs, elevations or dips/buttons, restraint cords)
- (12) Allow the elastomer to harden (approx. 24 hours)
- (13) To create the support mould/support shell, do not pull the shell mould off the model
- (14) Apply release agent as appropriate to the back of the shell mould if necessary and allow to dry
- (15) With back tapers, apply wedges/plugs made of the support mould material (plaster, fibre-reinforced resins) (epoxide/polyester) and make any necessary adjustments for the following support mould
- (16) Allow the plugs to sit on the shell mould
- (17) Apply release agent again and allow to dry
- (18) Apply support mould
- (19) If necessary, reinforce the support mould by applying wooden bars or steel sections
- (20) Allow the support mould to cure

**Further steps with embedded models:**

- Place the form on its back
- Remove the embedding material
- Leave the first half of the support mould and shell mould on the model

**With models placed down:**

- Remove the support rib

**Same further steps after the removal of the embedding or storage material****Second half of mould**

- If necessary, apply release agent to the model and visible inside surfaces of the first mould halves and rib
- Allow the release agent to dry
- (1-20) Work steps identical with first half of mould
- (21) Remove the support mould and shell mould halves from the model
- (22) Place the halves of the shell mould back into the halves of the support mould that they are precisely aligned
- (23) Clamp the halves of the support mould together in their precisely aligned position (plaster, mortar) or screw them together (polyester/epoxide)
- (24) Place the shell mould also back into the support mould every time once the replicas have been produced in order to prevent deformations, particularly on shell moulds where the reactions have not yet fully been allowed to run their course



*Ginkgo leaf concrete imprint modelled using PUR elastomer*

# Shell mould – two-piece, coat-and-smooth method, vertical

## Coat application

(PUR, Si)

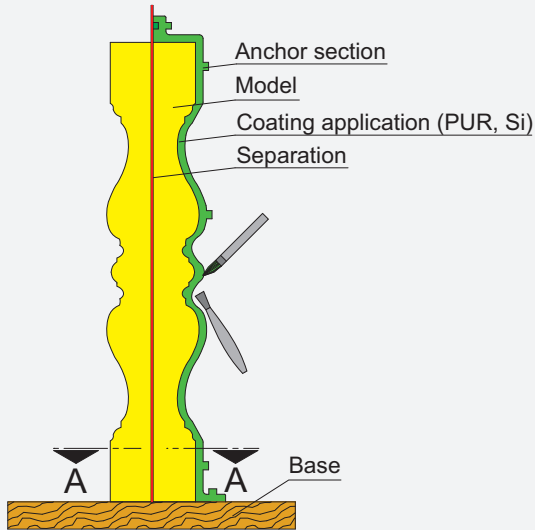

## Cross-section A-A

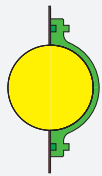

## Glass-fibre reinforced plastic application

(Polymer ramming material, polymer paste, polymer laminate)

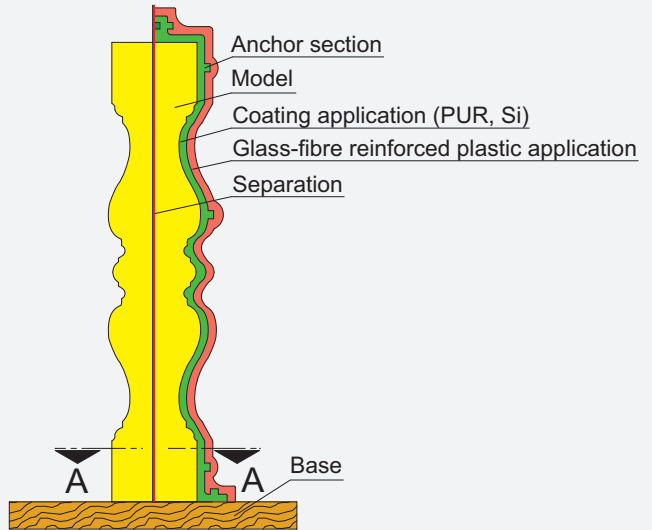

## Cross-section A-A

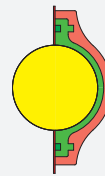

## Shell mould

(PUR, Si)

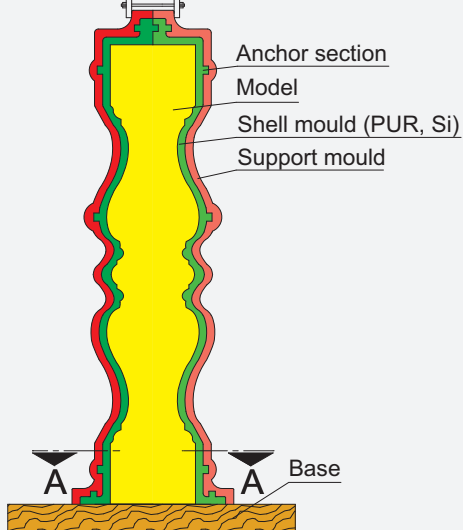

## Cross-section A-A



## Removal of form

Removed glass-fibre reinforced plastic support shell, elastomer mould

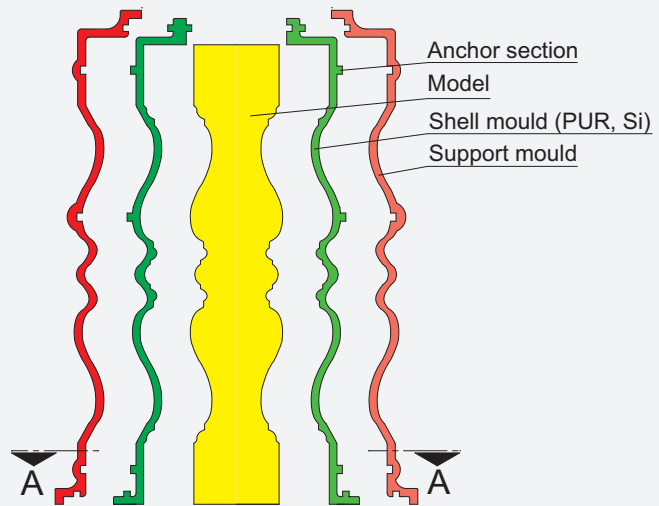

## Cross-section A-A

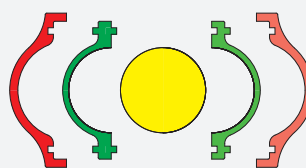

Reproduction (copy)  
(Plaster, concrete, polymer)

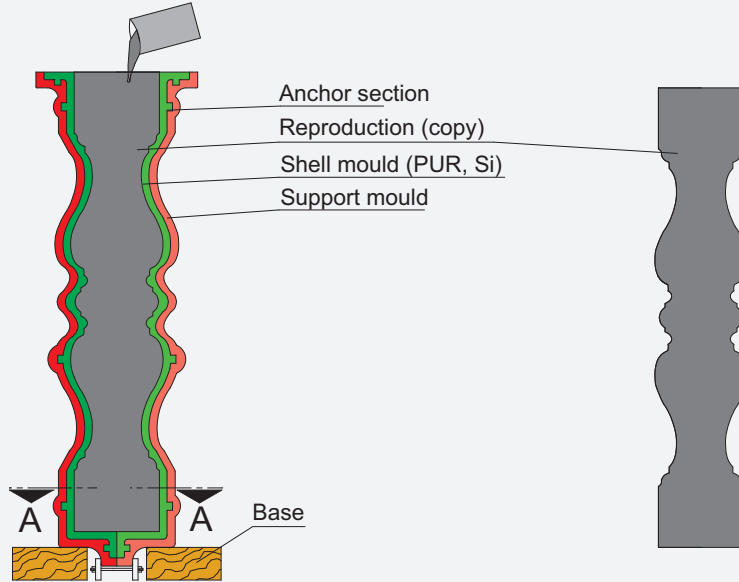

Cross-section A-A

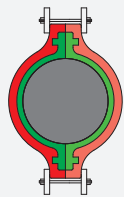

Cross-section A-A



Removal of a two-piece shell mould made of PUR elastomer



Two-piece shell mould with mould support

# Mould construction terminology

## Mould creation material

Material that is cast or applied to create a mould.

## Anchor / fixture / interlock

Interlocking connecting elements that ensure that moulds consisting of several parts align perfectly and that the mould and supporting shell are aligned.

## Reinforcement

Reinforcement of moulds and supporting shells by embedding or applying fabrics, wires, grating, wood etc.

## Spacer material

Clay, plasticine, plaster or other spreadable materials that are used for creating space between the model and the protective shell when creating the shell mould using the cast method and which determines how thick the shell is.

## Embedding material

Is required when producing the first half of a solid mould consisting of two or more pieces. It will generally be kiln-dried sand with plaster or cement mortar applied on top, in which the first half of the model is embedded as far as the established seam line. The spacer material can also be used as an embedding material.

## Mould

Depending on the model, an elastic or possibly rigid structure used to give reproduction materials their form.

## Casting frame

Frame formed as a container as a means of assistance; the casting materials are poured into this.

## Shell mould

Thin-walled, 5-20 mm thickness mould manufactured by casting or application.

## Solid mould

Highly stable thick-walled mould manufactured by casting.

## Model

The object to be moulded and then reproduced.

## Reproduction / copy / replica

A faithful copy of the original model.

## Reproduction material

Generally a castable material from which the reproduction is made.

## Support mould / supporting shell

A rigid support for the elastic mould, suitable for capturing the forces exerted during the moulding and reproduction process.

## Parting line

An arbitrary line on the model that defines two parts of a mould.



*Reconstruction of a forest elephant*

# How to select the appropriate mould technology

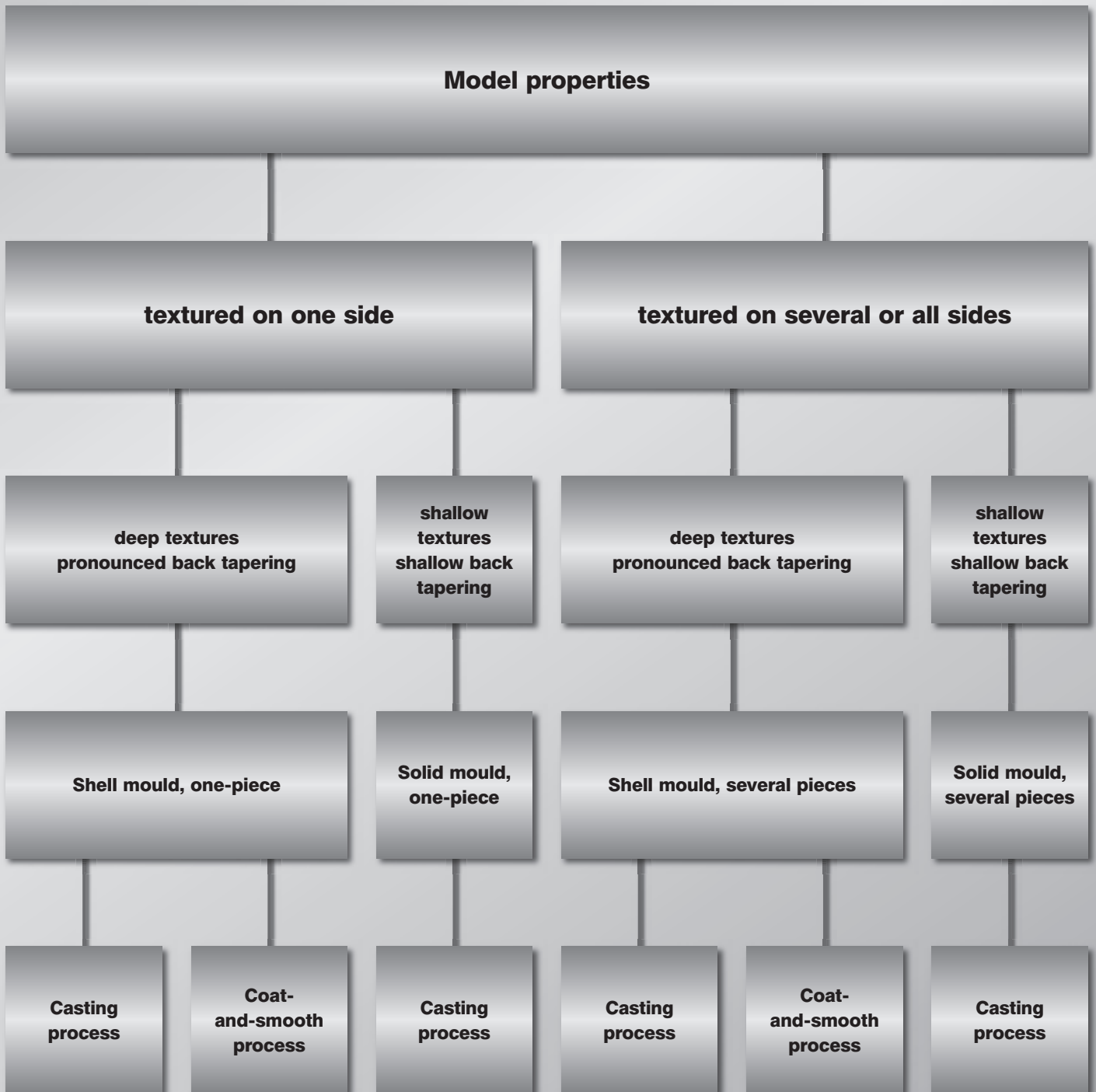

## Advantages of solid moulds

- Less work
- Better stability, especially with PUR elastomer moulds
- Simple to remove when manufacturing the mould and with later reproductions
- High resistance to wear and reproducing large quantities

## Advantages of shell moulds

- Less material needed
- Less force exerted during removal thanks to improved use of material-specific properties
- Possibility of creating complex shapes with extreme back tapers and dips
- Suitable as a mould reproduction technology for large-volume objects

# Mixture tables

Mixing ratio in weight parts			
8 : 1		10 : 1	
Base	Hardener	Base	Hardener
50 g	6.25 g	50 g	5.00 g
100 g	12.50 g	100 g	10.00 g
200 g	25.00 g	200 g	20.00 g
300 g	37.50 g	300 g	30.00 g
400 g	50.00 g	400 g	40.00 g
500 g	62.50 g	500 g	50.00 g
600 g	75.00 g	600 g	60.00 g
700 g	87.50 g	700 g	70.00 g
800 g	100.00 g	800 g	80.00 g
900 g	112.50 g	900 g	90.00 g
1000 g	125.00 g	1000 g	100.00 g
1100 g	137.50 g	1100 g	110.00 g
1200 g	150.00 g	1200 g	120.00 g
1300 g	162.50 g	1300 g	130.00 g
1400 g	175.00 g	1400 g	140.00 g
1500 g	187.50 g	1500 g	150.00 g
1600 g	200.00 g	1600 g	160.00 g
1700 g	212.50 g	1700 g	170.00 g
1800 g	225.00 g	1800 g	180.00 g
1900 g	237.50 g	1900 g	190.00 g
2000 g	250.00 g	2000 g	200.00 g
2500 g	312.50 g	2500 g	250.00 g
3000 g	375.00 g	3000 g	300.00 g
3500 g	437.50 g	3500 g	350.00 g
4000 g	500.00 g	4000 g	400.00 g
4500 g	562.50 g	4500 g	450.00 g
5000 g	625.00 g	5000 g	500.00 g
6000 g	750.00 g	6000 g	600.00 g
7000 g	875.00 g	7000 g	700.00 g
8000 g	1000.00 g	8000 g	800.00 g
9000 g	1125.00 g	9000 g	900.00 g
10000 g	1250.00 g	10000 g	1000.00 g

**Table 1** assumes that the base weight is available and adds the appropriate amount of hardener.



## Mixing ratio in weight parts

8 : 1		10 : 1			
Total mixture	Base	Hardener	Total mixture	Base	Hardener
50 g	44.44 g	5.55 g	50 g	44.45 g	4.55 g
100 g	88.88 g	11.11 g	100 g	90.90 g	9.10 g
200 g	177.77 g	22.22 g	200 g	181.80 g	18.20 g
300 g	266.00 g	33.00 g	300 g	272.75 g	27.25 g
400 g	355.00 g	44.00 g	400 g	363.65 g	36.35 g
500 g	444.00 g	55.00 g	500 g	454.55 g	45.45 g
600 g	533.00 g	66.00 g	600 g	545.45 g	54.55 g
700 g	622.00 g	77.00 g	700 g	636.35 g	63.65 g
800 g	711.00 g	88.00 g	800 g	727.25 g	72.75 g
900 g	800.00 g	100.00 g	900 g	818.20 g	81.80 g
1000 g	888.00 g	111.00 g	1000 g	909.10 g	90.90 g
1100 g	977.00 g	122.00 g	1100 g	1000.00 g	100.00 g
1200 g	1066.00 g	133.00 g	1200 g	1090.90 g	109.10 g
1300 g	1155.00 g	144.00 g	1300 g	1181.80 g	118.20 g
1400 g	1244.00 g	155.00 g	1400 g	1272.75 g	127.25 g
1500 g	1333.00 g	166.00 g	1500 g	1363.65 g	136.35 g
1600 g	1422.00 g	177.00 g	1600 g	1454.55 g	145.45 g
1700 g	1511.00 g	188.00 g	1700 g	1545.45 g	154.55 g
1800 g	1600.00 g	200.00 g	1800 g	1636.35 g	163.65 g
1900 g	1688.00 g	211.00 g	1900 g	1727.25 g	172.75 g
2000 g	1777.00 g	222.00 g	2000 g	1818.15 g	181.85 g
2500 g	2222.00 g	277.00 g	2500 g	2272.75 g	227.25 g
3000 g	2666.00 g	333.00 g	3000 g	2727.25 g	272.75 g
3500 g	3111.00 g	388.00 g	3500 g	3181.80 g	318.20 g
4000 g	3555.00 g	444.00 g	4000 g	3636.35 g	363.65 g
4500 g	4000.00 g	500.00 g	4500 g	4090.90 g	409.10 g
5000 g	4444.00 g	555.00 g	5000 g	4545.45 g	454.55 g
6000 g	5333.00 g	666.00 g	6000 g	5454.50 g	545.50 g
7000 g	6222.00 g	777.00 g	7000 g	6363.60 g	636.40 g
8000 g	7111.00 g	888.00 g	8000 g	7272.70 g	727.30 g
9000 g	8000.00 g	1000.00 g	9000 g	8181.80 g	818.20 g
10000 g	8888.00 g	1111.00 g	10000 g	9090.90 g	909.10 g

**Table 2** assumes the total mixture required and specifies the individual weights of the base and hardener components.

# Application examples



*PUR elastomer mould*



*Finished concrete element*



*Model of a rock texture*



*Artificial concrete rock wall*



*Tendrilled ornament – CNC milling technology with PUR elastomer moulds – white concrete elements*



*Ceiling made of concrete with Arab-style ornaments*



*The palm and fruits are concrete replicas*



*A map of the town of Naumburg*



1172 / 04/12 / MW



**RECKLI**<sup>®</sup>  
DESIGN YOUR CONCRETE

**RECKLI.COM**

RECKLI GmbH  
Gewerkenstr. 9a  
44628 Herne  
Germany  
T +49 2323 17 0 60  
F +49 2323 17 06 50  
info@reckli.com